

Farenhyt

SD505-DUCTR / SD505-DTS-K

Analog Duct Smoke Detector with Relay Module and Remote Test Switch

The SD505-DUCTR analog addressable duct smoke detector with built-in relay module detects products of combustion present in air moving through an HVAC system. The SD505-DUCTR is compatible with the SD505-DTS-K, which provides remote annunciation and testing capabilities for the SD505-DUCTR. The SD505-DTS-K uses the same key as the control panel.

The SD505-DUCTR is a heavy duty metal housing with a pre installed SD505-APS Analog Photo Electric Smoke Sensor and relay module. When smoke is detected in a duct, the unit communicates the condition to the FACP. The panel, in turn, depending on programming, turns off fans, blowers, and other devices.

Features

- Two-wire connection to SLC
- Detects and limits the spread of smoke
- Rugged steel backbox with clear plastic cover
- LED alarm indication and communication on sensor head
- No screens or filters to clean
- SD505-APS Photoelectric Smoke Detector pre-installed.
- 3 standard tube lengths
- Large terminal connection screws
- UL Listed

Compatible Control Panels

The SD505-DUCTR and SD505-DTS-K are compatible with the following FACP's:
IFP-1000 Intelligent Fire Panel
IFP-100 Intelligent Fire Panel
IFP-50 Intelligent Fire Panel

Duct Detector Housing with SD505-APS Analog Photoelectric Smoke Sensor and Relay and Remote Test Switch with key



MEA
429-92-E VOL. XI



SD505-DUCTR



SD505-DTS-K



7550 Meridian Circle, Suite 100
Maple Grove, MN 55369
763-493-6400 or 800-328-0103
Fax: 763-493-6475
www.farenhyt.com

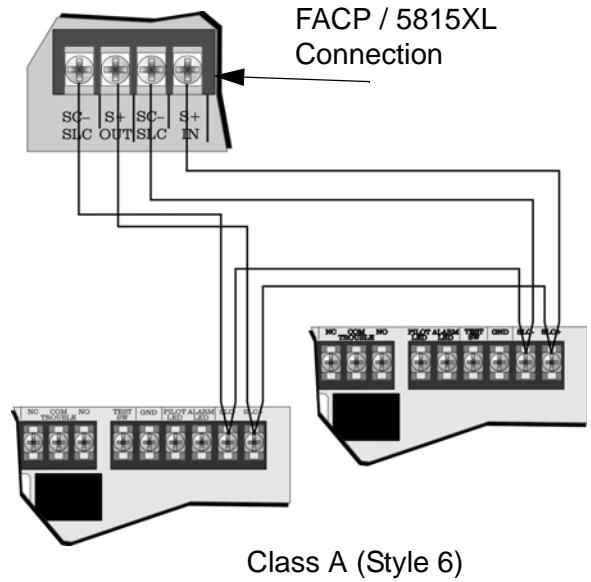
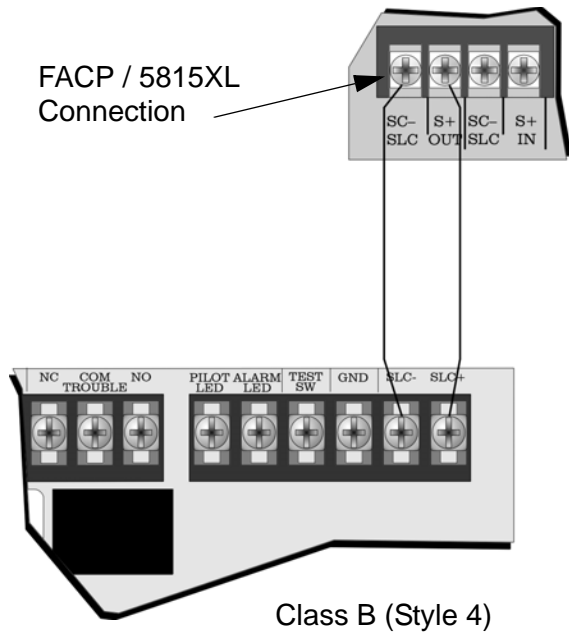

Specifications	Rating
SD505-DUCTR	
Alarm Relay Contact Rating	10A @ 24VDC 10A @ 115VAC 10A @ 240VAC
Trouble Relay Contact Rating	2.5A @30VDC
Operating Voltage	24VDC
Aux. Power Input Current	20mA Standby 62mA Alarm
SLC Input Current	0.5mA
Maximum SLS Resistance	50 Ohms
Operating Temperature	32°F - 100°F
Humidity	10% -85% RH Non-Condensing
Air Velocity Rating	300 - 4000 ft./min
Dimensions	91/8"L x 71/4"W x 21/4"H
Maximum Net Weight	3lbs
Sampling Tubes	2.5ft., 5ft, or 10ft

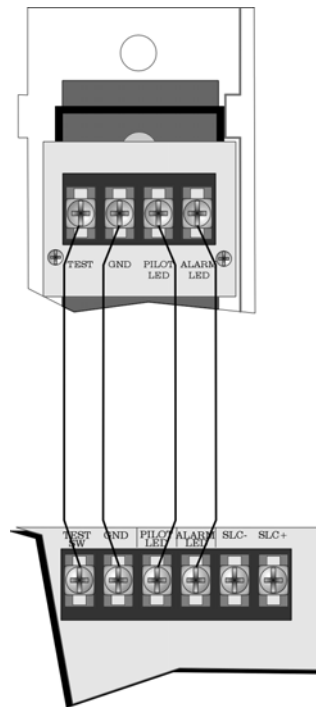

SD505-DTK-K Specifications

Dimensions: 4.5"H x 2.75" W x 1-5/8" D
Color: Red



This document is not intended to be used for installation purposes. We try to keep our product information up-to-date and accurate. We cannot cover all specific application or anticipate all requirements. All specifications are subject to change without notice. For more information contact Silent Knight 7550 Meridian Circle, Suite 100, Maple Grove, MN 55369-4927 Phone: (763)-493-6400 or (800) 328-0103, fax (763) 493-6475
www.farenhyt.com



Made in the U.S.A.