

# Farenhyt

## SSB224BI

The SSB224BI is a 6" mounting base with a built-in isolator for IDP-series detectors intended for use with the IFP-series fire alarm control panels (FACPs). The SSB224BI prevents an entire communication loop from being disabled when a short circuit occurs. The SSB224BI isolates any part of a loop that has a short from the rest of the loop. The base also automatically restores the entire loop when the cause of the short circuit is corrected.

### Features

- Isolate up to 25 IDP-series devices between each SSB224BI
- Support for Class A and Class B wiring
- Fully supervised
- Plug-in mounting provides ease of installation
- Tamper-proof feature prevents removal of the detector without the use of a tool
- Range of mounting options to meet any application
- B501 allows for aesthetically pleasing installation with Recessed Mounting Kit (PN SSRMK400)
- SEMS screws and wire gauge 22–14 AWG
- UL Listed

### Installation

The SSB224BI can be mounted on a variety of junction boxes as shown in the table below.

Junction Box Selection Guide\*

| U.S. Junction Boxes   |          |         |       |
|-----------------------|----------|---------|-------|
| Single Gang           | 3.5" Oct | 4" Oct† | 4" Sq |
| No                    | Yes      | Yes     | Yes   |
| Metric Boxes Junction |          |         |       |
| 50 mm                 | 60 mm    | 70 mm   | 75 mm |
| No                    | No       | Yes     | Yes   |

\* Box depth is contingent on base and wire size. Refer to the National Electric Code or applicable local codes for appropriate recommendations.

† With 3.0 mud ring.

Addressable Isolator Base



SSB224BI Isolator Base (Detector Not Included)

### Compatibility

The SSB224BI is compatible with the following IDP-series detectors:

- IDP-Photo Photoelectric Smoke Detector
- IDP-Photo-T Photoelectric Smoke Detector with Thermal
- IDP-Acclimate Multicriteria Photoelectric Smoke Detector
- IDP-Ion Ionization Smoke Detector
- IDP-Heat Fixed Temperature Thermal Detector
- IDP-Heat-ROR Rate-of-Rise Detector with Thermal
- IDP-Heat-HT Fixed High Temperature Thermal Detector

The SSB224BI is compatible with the following FACPs:

- IFP-2000/RPS-2000 Intelligent Fire Panel
- IFP-1000 Intelligent Fire Panel
- IFP-100 Intelligent Fire Panel
- IFP-50 Intelligent Fire Panel

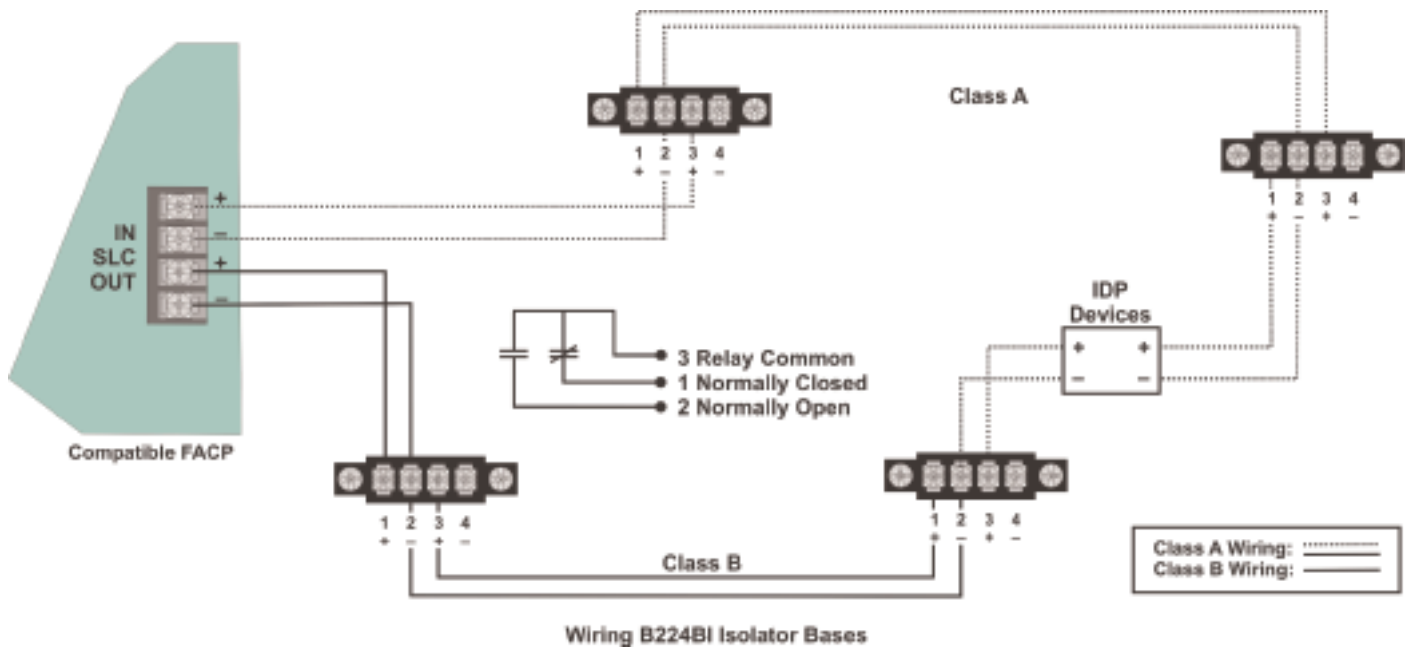

## Specifications

### Physical

Height: 1.2" (3.1 cm)  
 Diameter: 6.1" (15.5 cm)

### Electrical

Wire Gauge: 22-14  
 Operating Voltage: 15 – 32 VDC  
 Standby Current: 450  $\mu$ A max @ 24 VDC

### Environmental

Operating Temperature: 14°F – 140°F (-10°C – 60°C)  
 Normal Ambient Temperature: 32°F – 120°F (0°C – 49°C)  
 Humidity: 10% – 93% non-condensing

## Ordering Information

SSB224BI 6" Isolator Base

## Accessories

|               |  |
|---------------|--|
| SSRMK400      | Recessed Mounting Kit. Provides low profile for use with B501.   |
| SSXR2B        | Detector Removal Tool. A removal and replacement tool for IDP plug-in detectors. Includes the T55-127-000. |
| SSM02-04-01   | Detector Test Magnet.  |
| SSM02-09-00   | Test Magnet with Telescoping Handle.   |
| SSXP-4        | Extension Pole for XR2B. Extends from 5 – 15 ft.   |
| SST55-127-000 | Detector Removal Head  |
| SSBCK-200B    | Black Detector Kit. For IDP-series detectors.  |

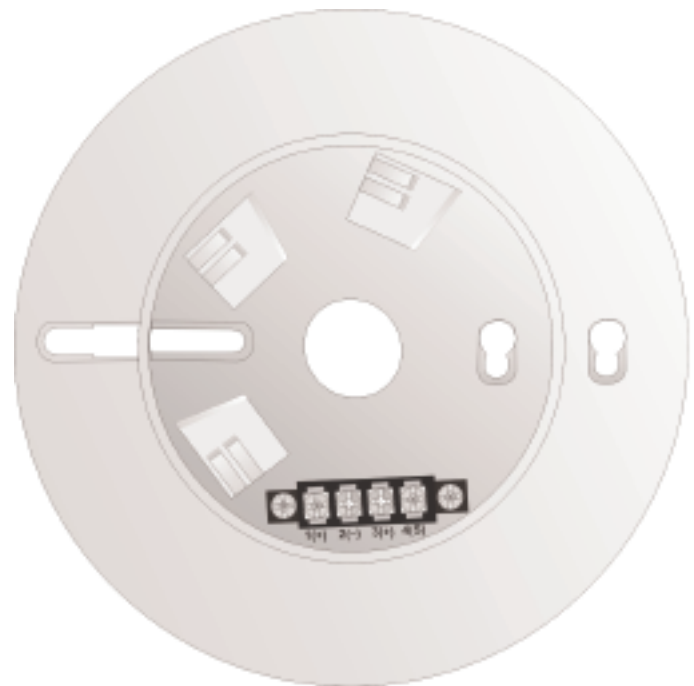

Top View of SSB224BI Isolator



This document is not intended to be used for installation purposes. We try to keep our product information up-to-date and accurate. We cannot cover all specific applications or anticipate all requirements. All specifications are subject to change without notice. For more information, contact Silent Knight 7550 Meridian Circle Suite 100, Maple Grove, Mn 55369-4927. Phone: (800) 328-0103, Fax: (763) 493-6475. [www.farenhyt.com](http://www.farenhyt.com)



Made in the U.S.A.